

LINEAR RESPONSE

INVISIBLE SPEAKERS & SUBWOOFERS



STEALTH ACOUSTICS



A BRIEF HISTORY OF STEALTH ACOUSTICS

There have been great strides in the invisible speaker category recently, but Stealth Acoustics remains *THE* industry leader. Founded in 2003 to launch its first speaker, but with roots back to the '70s, Stealth Acoustics remains years ahead of the competition by focusing on reliability, ultimate performance, and minimal aesthetic impact.

As a division of Dimensional Communications, Inc., a premier systems integration company based in Washington State (USA), Stealth Acoustics has had systems integration at its core since the beginning. Stealth has leveraged nearly 50 years of direct experience from countless systems integration projects to become a world-class audio/video manufacturer by understanding the needs of systems integrators.

Stealth introduced its most comprehensive lineup of invisible speakers in 2013, the 6th-generation LineaResponse G Series speakers, along with the only invisible subwoofers, the LineaResponse Bg Series. In 2017 the lineup expanded to include the performance-oriented, 7th-generation LineaResponseX Series.

Today there is a LineaResponse speaker model to fit the needs of any project: from surround sound installations and family rooms to offices and bedrooms - residential and commercial. Stealth has the product depth, the history of reliability, and the information and resources available to make every project successful!

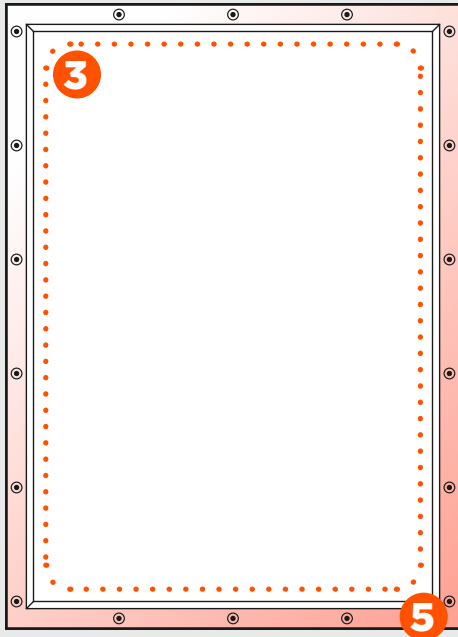

Anatomy of a Stealth Invisible Speaker

- 1 Transducer High/Mid Frequency Driver
- 2 Low Frequency Cone Woofer Driver
- 3 FidelityGlass™ Radiating Diaphragm
- 4 Circuit with Crossover, Protection and/or Speaker Wire Terminals
- 5 Speaker Perimeter Screw Flange

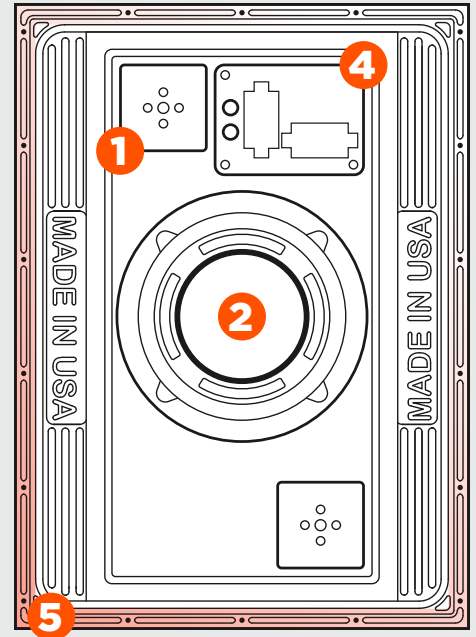

All LineaResponse speakers are handmade in the USA. They feature an innovative design, quality hardware, and Stealth's patented FidelityGlass™ face panel material to achieve industry-leading performance metrics and a 170-degree sound dispersion pattern that makes them the benchmark for all invisible speakers.

Stealth Acoustics LineaResponse invisible speakers are constructed in the USA with high-quality materials. With proper installation and care, LineaResponse speakers will last a lifetime.

LINEARESPONSE TECHNOLOGY

LineaResponse invisible speakers use a combination of three sound-generating technologies. The first (and common to all other invisible speaker products currently on the market) is the direct coupling of an exciter/transducer driver to the speaker's front surface panel (radiating diaphragm). This method works very well for higher frequencies, but direct-coupled transducers become less efficient as the frequency drops and limit bass response.

Second, Stealth combines the direct-coupled transducer technology with an acoustic lever technology driven by a traditional woofer to overcome the loss of bass response. The acoustic lever energizes the radiating diaphragm of the speaker panel for impactful bass. The greater surface area translates to a lower frequency response.

The third technology is the unique FidelityGlass™ radiating diaphragm. Stealth Acoustics developed FidelityGlass™ as a flat, durable, proprietary material with superior sound reproduction characteristics that also allows the speakers to finish invisibly into a wall.

INSTALLATION

The typical installation process is similar to making a wallboard patch. The speaker is attached directly to the structural framing of a wall or ceiling then the seams are finished with tape and mud using standard wall finishing techniques. Finishes such as texture, paint, thin fabric, wallpaper, and veneer create a completely invisible audio experience.

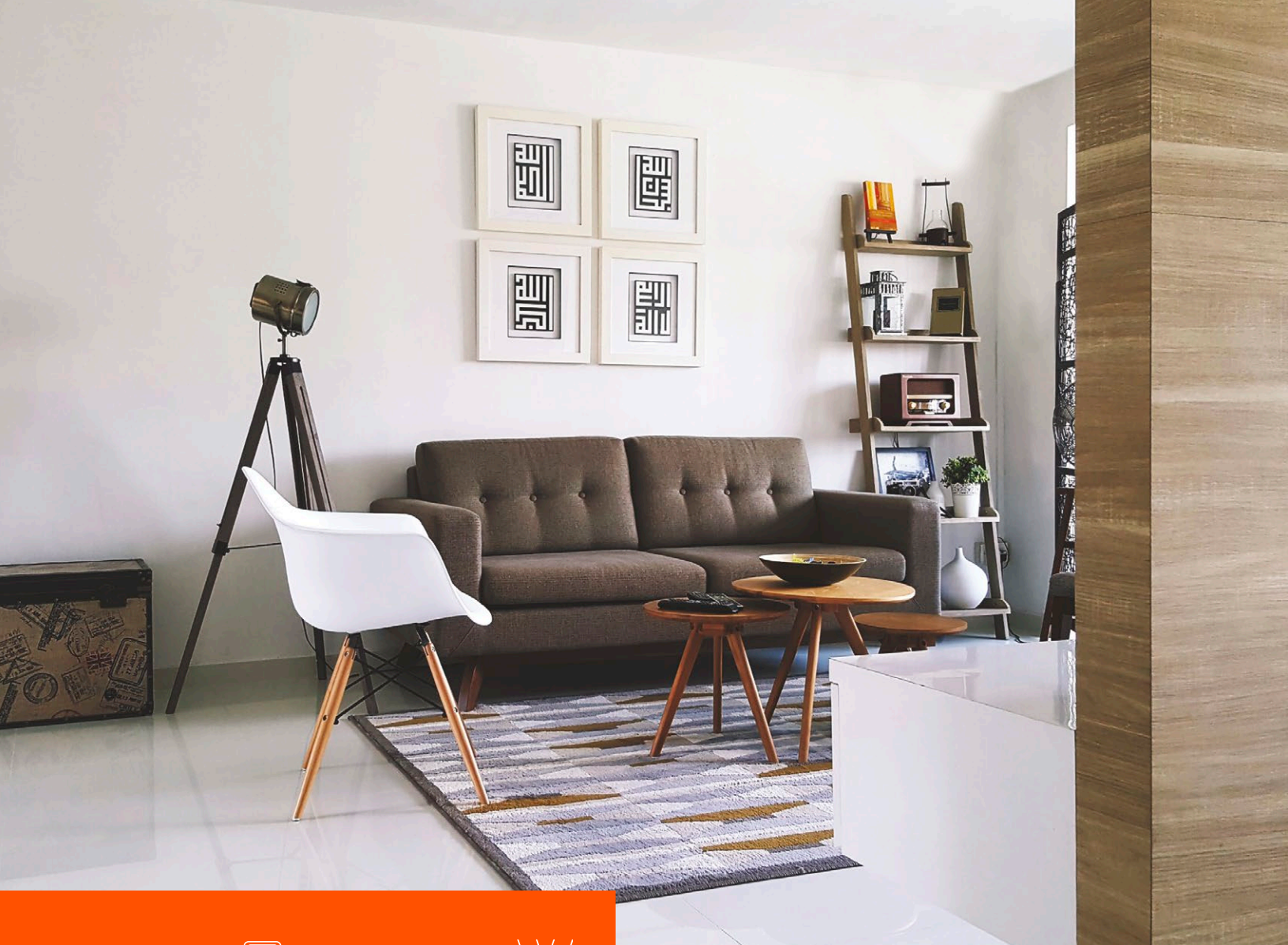

LINEA **R**ESPONSE X
INVISIBLE SPEAKERS - EXPERT GRADE

EXPERT GRADE INVISIBLE AUDIO

LineaResponseX™ (LRX) expert-grade invisible speakers from Stealth Acoustics feature the FidelityGlass Advanced™ mechanically tuned diaphragm and lamination processes and enhanced driver sets. The LRX Series adds to Stealth's growing family of high-performing, incredible-sounding invisible speakers.

For demanding audiophiles that seek impeccable audio performance yet desire the aesthetic benefits that only true invisibility can offer, Stealth's new LRX range raises the bar for invisible speakers to an unprecedented level.

HIGH PERFORMANCE LISTENING & CINEMA

LRX85

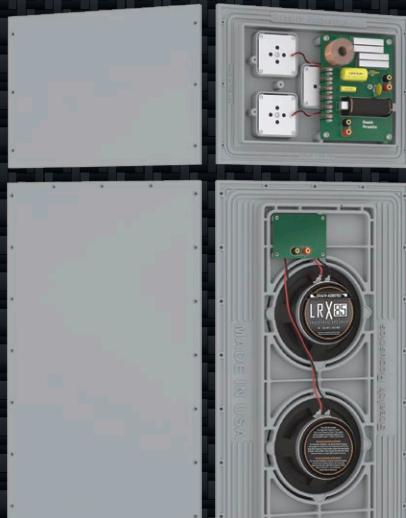

HIGH PERFORMANCE DISTRIBUTED AUDIO

LRX83

▶ The Best All-Purpose Speaker!

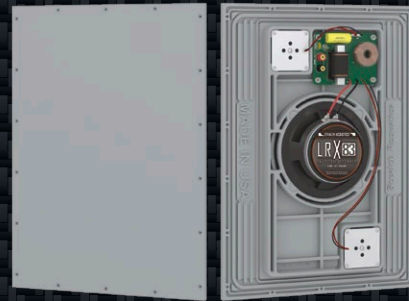

3-WAY FULL-RANGE SEVEN-ELEMENT SYSTEM

The LRX-85 is Stealth's flagship loudspeaker. Its component-style design (separate low and high-frequency panels) allows for a high level of articulation and output. There has never been an invisible speaker experience like this before.

This "Big-Room" speaker system tops them all by offering smooth frequency extension from 20kHz to a bone-shaking 35Hz.

For even higher performance, the LRX-85 can accommodate a bi-amp configuration.

Recommended Applications:

Cinema Front Soundstage (LCR), Premium Distributed Audio and Sound Reinforcement. Best for in-wall or in-ceiling installations.

▶ The Flagship "Big-Room" Speaker!
(includes 2 panels)

3-WAY HIGH PERFORMANCE INVISIBLE LOUDSPEAKER

The LRX-83 is designed to be the ultimate invisible whole-house audio speaker and has become one of the most significant products in the Stealth portfolio.

Used as an LCR or Cinema Surround system, the LRX-83 will put you right in the middle of the action. Used as a premium distributed audio solution, the LRX-83 will fill an entire home with studio-quality sound without a single visible speaker grill.

The proprietary FidelityGlass™ radiating diaphragm allows for smooth frequency extension to 20kHz and will play down to 40Hz with proper installation techniques.

Recommended Applications:

Premium Distributed Audio and Sound Reinforcement, Cinema Front Soundstage (LCR), Cinema Surround

WORRY FREE OPERATION

All LineaResponse LRX and LRg Series speakers utilize independent, self-resetting protection circuits. In case of excessive amplifier output, the protection circuits interrupt the signal preventing damage to the speaker. Once the amplifier output has been reduced, the protection circuits self-reset to allow the speakers to function normally.



LINEA **R**ESPONSE

INVISIBLE SPEAKERS & SUBWOOFERS

NO COMPROMISE INVISIBLE AUDIO

Stealth Acoustics LineaResponse G™ (LRg) are cost-effective, proven invisible loudspeakers that rival the sound quality of comparably priced visible speakers.

The award-winning LRg series is a no-compromise invisible audio solution boasting broad coverage and ultra-smooth extended frequency response. The LRg family of products features four full-range, reliable speakers for nearly any requirement.

PREMIUM LISTENING & CINEMA

LR3G

▶ The Original Invisible LCR!



DISTRIBUTED AUDIO

LR8G

▶ The Economical Whole-House Audio Choice!

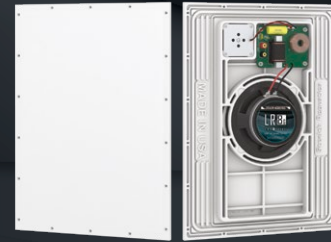

3-WAY FULL RANGE

Voiced specifically for mid-range/high frequency articulation, the LR3g is an excellent choice for cinema applications - especially for use as LCR speakers.

The Stealth Acoustics LR3g incorporates an acoustically coupled, high-power, 8" cone woofer with three directly coupled high/mid frequency drivers.

The proprietary FidelityGlass™ radiating diaphragm allows for smooth frequency extension to 20kHz and will play down to 40Hz with proper installation techniques.

Recommended Applications:

Cinema Front Soundstage (LCR), Premium Distributed Audio and Sound Reinforcement. Best for in-wall installations.

2-WAY FULL RANGE

The LR8g is Stealth's the most popular invisible distributed audio speaker. It features robust bass output and performs well at any volume level.

The Stealth Acoustics LR8g incorporates an acoustically coupled, high-power, 8" cone woofer with one directly coupled high frequency driver.

Stealth's proprietary FidelityGlass™ radiating diaphragm allows for smooth frequency extension to 20kHz, and will play down to 45Hz with proper installation techniques.

Recommended Applications:

Distributed Audio , Cinema Surround, Sound Masking
Best for in-wall or in-ceiling installations.

WORRY FREE OPERATION

All LineaResponse LRX and LRg Series speakers utilize independent, self-resetting protection circuits. In case of excessive amplifier output, the protection circuits interrupt the signal preventing damage to the speaker. Once the amplifier output has been reduced, the protection circuits self-reset to allow the speakers to function normally.



▶ The Stereo Single Point Source Speaker!

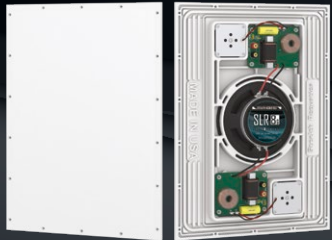

▶ The Compact Background Music Speaker!



2-WAY STEREO FULL RANGE

The SLR8g is a fantastic choice for installations where space is at a premium. The SLR8g utilizes a dual voice coil design offering stereo performance from a single speaker location.

The Stealth Acoustics SLR8g incorporates an acoustically coupled, high-power, dual-voice coil, 8" cone woofer with two directly-coupled high-frequency drivers.

The proprietary FidelityGlass™ radiating diaphragm allows for smooth frequency extension to 20kHz and will play down to 45Hz with proper installation techniques.

Recommended Applications:

Distributed Audio, Cinema Surround, Sound Masking
Best for in-wall or in-ceiling installations.

2-WAY COMPACT FULL RANGE

The LR6g is a compact, background music application invisible speaker. Its small footprint makes for easy installation into almost any location. Combine this speaker with the B22g subwoofer for an excellent 2.1 system.

The Stealth Acoustics LR6g incorporates an acoustically coupled, high-power, 6.5" cone woofer with one directly-coupled high-frequency driver.

The proprietary FidelityGlass™ radiating diaphragm allows for smooth frequency extension to 20kHz and will play down to 45Hz with proper installation techniques.

Recommended Applications:

Background Distributed Audio
Best for in-wall or in-ceiling installations.



2-CHANNEL AMPLIFIER

The SA2400MKII is a 2-channel, high-current amplifier. DSP settings for all Stealth speakers are pre-programmed for easy deployment.

Power Output (per channel - both channels driven):

310 watts @ 8Ω < 0.05 THD
450 watts @ 4Ω < 0.05 THD



MONAURAL AMPLIFIER

The SA250MKII is a monaural amplifier with a low pass filter designed specifically to power Stealth's invisible and outdoor subwoofers.

Mono Power Output:

250 watts @ 8Ω < 0.05 THD
350 watts @ 4Ω < 0.05 THD

PREMIUM SUBWOOFER

B30g

- ▶ The Premier Invisible Subwoofer System!
(includes 2 panels)



DISTRIBUTED AUDIO SUBWOOFER

B22g

- ▶ The Compact Subwoofer for use with LR6g!
(includes 2 panels)



INVISIBLE BASS

Stealth's LineaResponse B™ (Bg) Series Subwoofer systems deliver bold bass output for extra impact with zero aesthetic pollution. The full-sized B30g and compact B22g are 2-panel systems that install invisibly into the walls or ceiling of a room. These subs provide exceptional bass that listeners desire and excellent room coverage with frequencies extending as low as 20Hz.

SUBWOOFER SYSTEM

The B30g is a two-panel monaural subwoofer system ideal for theater/cinema applications or whole-house audio systems that require extra bass output. It features four acoustically coupled, high-power, 8" cone woofers per system.

The proprietary FidelityGlass™ radiating diaphragm allows for smooth frequency extension to 160Hz and will play down to 20Hz with proper installation techniques.

The B30g is a two-panel system. Both panels should be installed and wired according to the instructions. Stack them in corners or spread them throughout the room for the best coverage and performance.

Recommended Applications:

Premium Distributed Audio, Distributed Audio, High Performance & Cinema
Best for in-wall installations.

COMPACT SUBWOOFER SYSTEM

The B22g is a two-panel monaural subwoofer system perfect for pairing with the model LR6g to supplement low-frequency output in distributed audio applications. It features two acoustically coupled, high-power, 8" cone woofers per system.

The proprietary FidelityGlass™ radiating diaphragm allows for smooth frequency extension to 150Hz and will play down to 30Hz with proper installation techniques.

The B22g is a two-panel system. Both panels should be installed and wired according to the instructions. Stack them in corners or spread them throughout the room for the best coverage and performance.

Recommended Applications:

Background Distributed Audio, designed for use with the LR6g for extra impact in critical listening zones.
Best for in-wall or in-ceiling installations.



Veneer



Plaster



Wallpaper

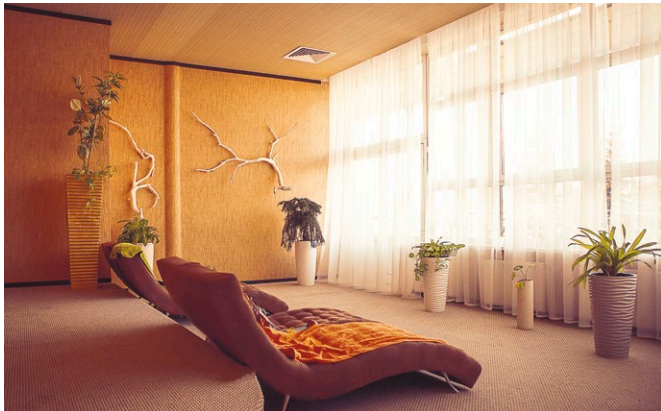

FINISHING OPTIONS

Stealth's Invisible Speakers are compatible with many wall-finishing methods. A flat finish or orange peel texture with latex paint is the most common, but other finish options may include lightweight plaster, wallpaper, veneer, or fabric. (See installation instructions for more details.)

Speaker Application Guide

	Invisible Indoor							
	LRX-85	LRX-83	LR3g	LR8g	SLR8g	LR6g	B30g - Sub	B22g - Sub
Residential Audio								
Cinema LCR								
Cinema Surround / ATMOS / FX								
2-Channel / Listening Rooms								
Subwoofer - Performance / Cinema								
Subwoofer - Background								
Distributed Audio								
Premium & Primary Zones								
Secondary Zones								
Background & Small Rooms								
High Ceiling & Entryway								
Outdoor Zones - Invisible								
Outdoor Zones - Visible								
Commercial Audio								
Constant Voltage (CVS)								
Sound Reinforcement								
Sound Masking								

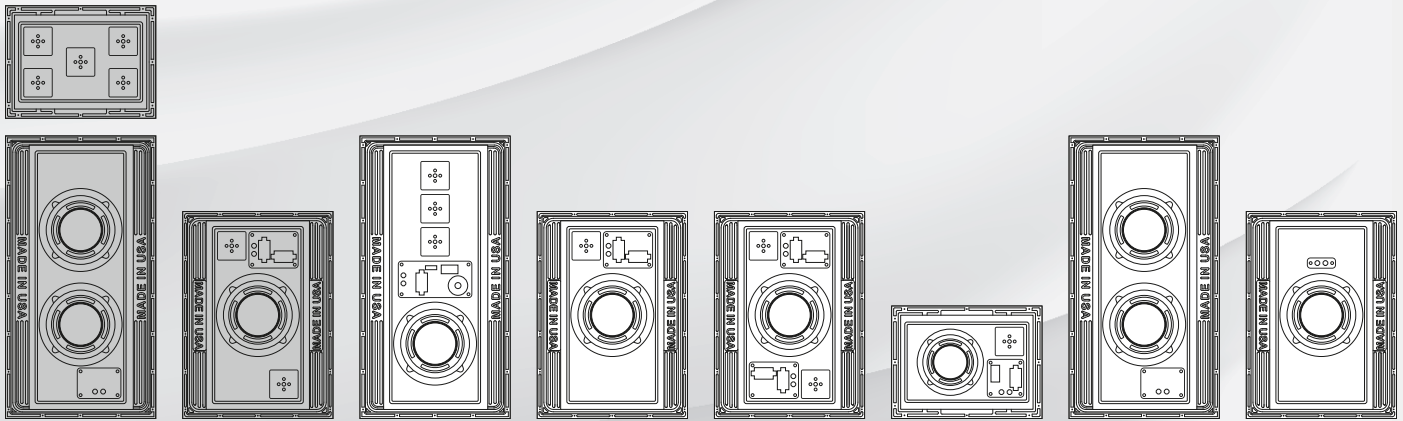

INVISIBLE SPEAKERS

	LR3G 3-way Full Range Speaker	LR8G 2-way Full Range Speaker	SLR8G Stereo Speaker	LR6G 2-way Full Range Speaker
Power Capacity	200 watts RMS	120 watts RMS	120 watts RMS per channel	100 watts RMS
Min. Recommended Power	75 watts	60 watts	60 watts per channel	50 watts
Frequency Response	40Hz to 20kHz	45Hz to 20kHz	45Hz to 20kHz	45Hz to 20kHz
Crossover	Passive 3-way	Passive 2-way	Passive 2-way	Passive 2-way
System Impedance	8Ω nominal	8Ω nominal	8Ω nominal	8Ω nominal
Sensitivity (1 meter @ 1 watt)	83 dB	83 dB	82 dB	83 dB
Polar Dispersion	170 degrees horizontal & vertical	170 degrees horizontal & vertical	170 degrees horizontal & vertical	170 degrees horizontal & vertical
Protection	(3) independent self-resetting devices (low, midrange and high frequency)	(2) independent self-resetting devices (low and high frequency)	(4) independent self-resetting devices (low and high frequency each channel)	(2) independent self-resetting devices (low and high frequency)
High Frequency Driver	(1) 1" (25mm) neodymium driver	(1) 1 1/8" (30mm) neodymium driver	(2) 1 1/8" (30mm) neodymium drivers	(1) 1 1/8" (30mm) neodymium drivers
Midrange Frequency Driver	(2) 1 1/8" (30mm) neodymium drivers	-	-	-
Low Frequency Driver	(1) 1 1/2" (38mm) voice coil 8" (203mm) woofer	(1) 1 1/2" (38mm) voice coil 8" (203mm) woofer	(1) 1 1/2" (38mm) voice coil 8" (203mm) woofer	(1) 1" (25mm) voice coil, 6.5" (165mm) woofer
Magnet	(1) ceramic 20 oz.	(1) ceramic 20 oz.	(1) ceramic 20 oz.	(1) ceramic 15 oz.
Width	15 7/8" (403 mm)	15 7/8" (403 mm)	15 7/8" (403 mm)	15 7/8" (403 mm)
Height	30" (762 mm)	22" (559 mm)	22" (558 mm)	11 7/8" (302 mm)
Depth	2 1/2" (64 mm)	2 1/2" (64 mm)	2 1/2" (64 mm)	2 1/4" (57 mm)
Weight	20 lbs. (9 kg) each	14 lbs. (6.3 kg) each	14.5 lbs. (6.6 kg) each	8.7 lbs. (3.9 kg) each

EXPERT GRADE INVISIBLE SPEAKERS

INVISIBLE SUBWOOFERS

	LRX-85 Full Range 7-Element Expert Grade Speaker System	LRX-83 3-way Full Range Expert Grade Speaker	B30G Subwoofer System	B22G Compact Subwoofer System
Power Capacity	300 watts RMS	160 watts RMS	240 watts RMS (per pair)	160 watts RMS (per pair)
Min. Recommended Power	120 watts	80 watts	120 watts (per pair)	100 watts (per pair)
Frequency Response	35Hz to 20kHz	40Hz to 20kHz	20Hz to 160Hz	30Hz to 150Hz
Crossover	Passive 3-Way @ 500Hz and 3kHz (asymmetrical)	Passive 3-way	Requires amplifier with low pass filter 50Hz with 18 dB slope recommended	Requires amplifier with low pass filter 80Hz with 18 dB slope recommended
System Impedance	8Ω nominal	8Ω nominal	16Ω or 4Ω (selectable)	8Ω nominal
Sensitivity (1 meter @ 1 watt)	84 dB	83 dB	86 dB	86 dB
Polar Dispersion	170 degrees horizontal & vertical	170 degrees horizontal & vertical	170 degrees horizontal & vertical	170 degrees horizontal & vertical
Protection	(3) independent self-resetting devices (low, midrange and high frequency)	(2) independent self-resetting devices (low and high/mid frequency)	-	-
High Frequency Driver	(1) 1" (25mm) neodymium driver	(1) 1" (25mm) neodymium driver	-	-
Midrange Frequency Driver	(4) 1" (30mm) neodymium driver	(1) 1 1/8" (30mm) neodymium driver	-	-
Low Frequency Driver	(2) 1 1/2" (38mm) voice coil 8" (203mm) woofer	(1) 1 1/2" (38mm) voice coil 8" (203mm) woofer	(2) 1 1/2" (38mm) voice coil 8" (203mm) woofers	(1) 1 1/2" (38mm) voice coil 8" (203mm) woofer
Magnet	(2) ceramic 20 oz. (622 gr)	(1) ceramic 20 oz.	(2) ceramic 20 oz.	(1) ceramic 20 oz.
Width	15 7/8" (403 mm) 15 7/8" (403 mm)	15 7/8" (403 mm)	15 7/8" (403 mm)	15 7/8" (403 mm)
Height	30" (762 mm)	12" (305 mm)	22" (559 mm)	22" (558 mm)
Depth	2 1/2" (64 mm)	2 3/4" (70 mm)	2 1/2" (64 mm)	2 1/2" (64 mm)
Weight	61 lbs. (28 kg) per pair (4 panels)	14 lbs. (6.3 kg) each	40 lbs. (18.2 kg) each pair (two panels)	28 lbs. (12.7 kg) each pair (two panels)

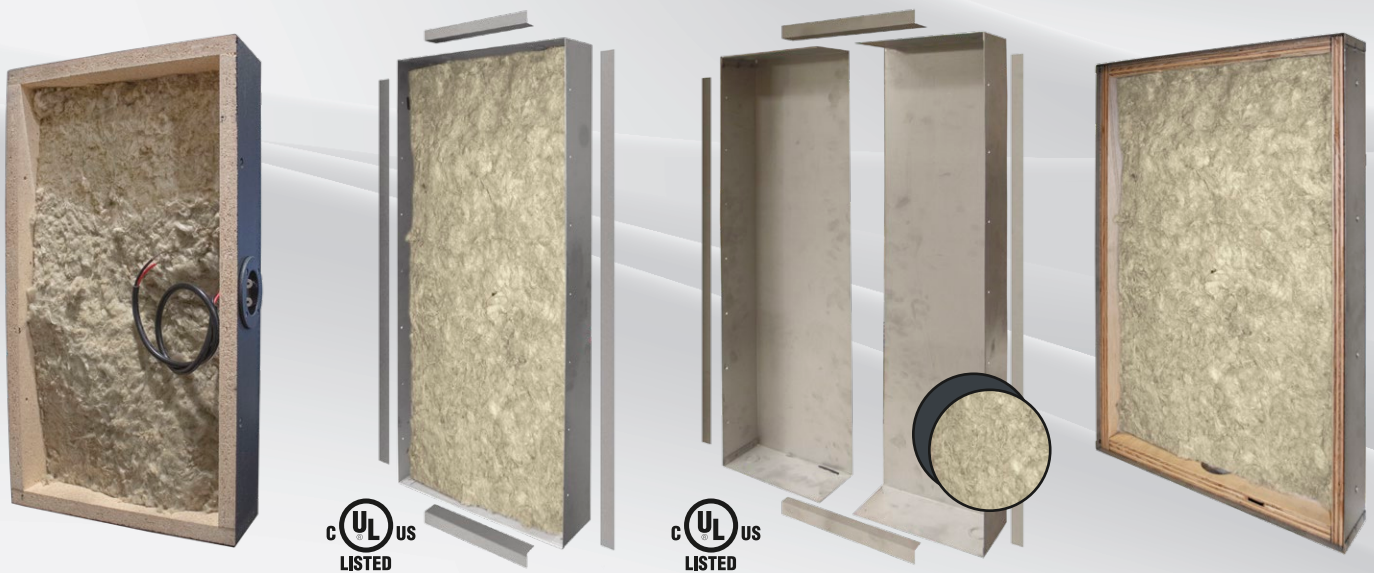

c UL US LISTED

c UL US LISTED

*Includes insulation and viscoelastic polymer mat.

BACK BOXES, PLACESAVERS, AND FLOATING BRACKETS

Stealth manufactures four styles of speaker back boxes designed to suit any construction type. Back boxes help the speakers achieve optimum performance and may also be required to meet construction codes.

Wood Back Box

BX series insulated wooden back boxes are available for all models of invisible speakers and help the speaker achieve optimum performance. BX back boxes are ideal for retrofit installations, locations with narrow framing, and where plenum ratings are not a concern. The 3½" deep back box ships fully assembled and attaches directly to the back of the speaker during speaker installation.

Metal Back Box - Fixed Width

MBX insulated back boxes are UL Listed, plenum rated, and designed to fit snugly between 16" (406 mm) on-center framing and may be installed during the pre-wire phase or as a retrofit. MBX back boxes include mounting hardware for hat channel-type suspended ceiling applications and metal stud framing.

Metal Back Box - Adjustable Width

MBA insulated back boxes are UL Listed, plenum rated, and adjustable width to fit between irregular framing and may be installed during the pre-wire phase or as a retrofit. MBA back boxes include mounting hardware for hat channel-type suspended ceiling applications and metal stud framing.

Metal Back Box - Solid Wall Type

MBC back boxes create a solid mounting surface for invisible speakers where there may not otherwise be support. MBC back boxes are ideal for installation locations such as masonry and hat-channel-type suspended ceilings. Additionally, use an MBC back box where there is open space behind a speaker or where a metal enclosure behind the speaker is required.



PlaceSaver™

Install PlaceSaver™ in new construction when the job is pre-wired. PlaceSaver™ reserve space for the speaker during wallboard installation and prevents the speaker panel itself from exposure to a harsh construction environment.



Floating Bracket

The Floating Brackets create a solid mounting surface for LR6g invisible speakers with framing greater than 16" (406 mm) on-center. Floating Brackets should be installed before wall finishing. Each kit contains the bracket, mounting hardware, and a PlaceSaver™ PS-12.

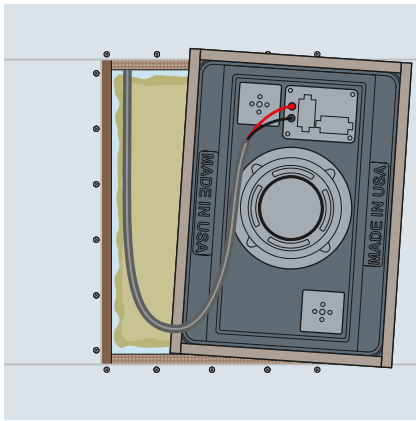

Prep & Wire

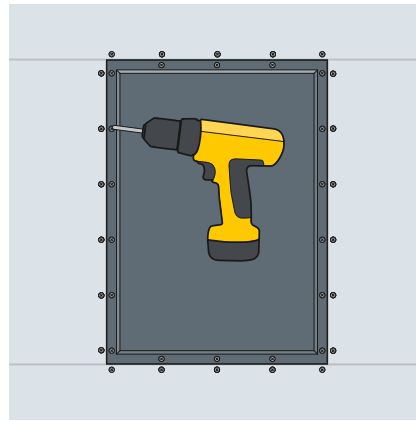

Attach & Adjust



Test with Music!

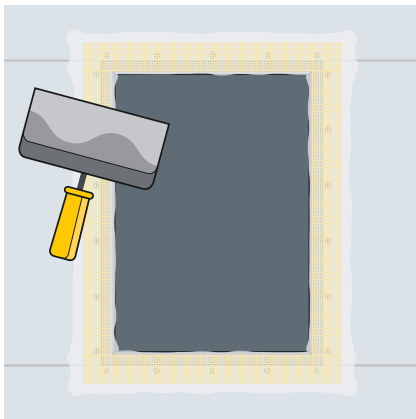

Tape & Mud

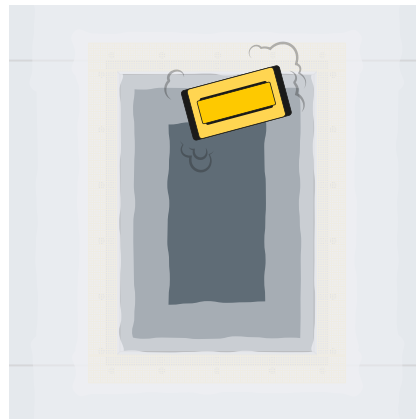

Sand & Inspect

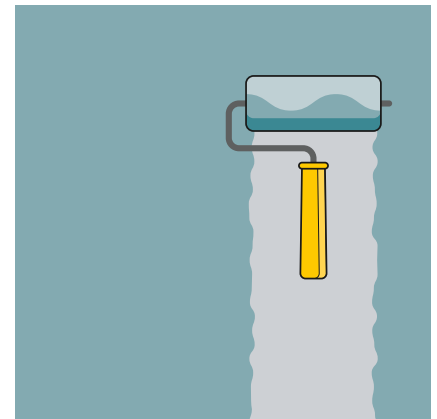

Prime & Paint

CORRECT REGISTRATION

Verify proper installation before wall finishing.
Hold a straight edge across the speaker face to verify 1/16" (2mm) gap on all sides.

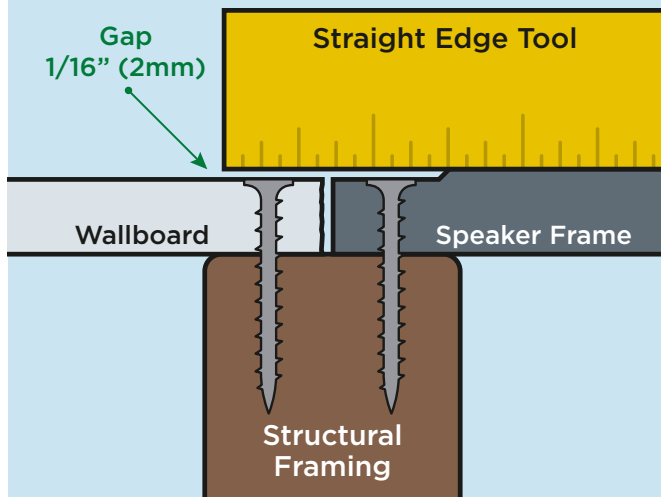

INSTALLATION OVERVIEW

The FidelityGlass™ face of an Invisible Speaker is smooth and durable, designed to finish seamlessly with the surrounding wallboard.

The installation process is as simple as fitting a drywall patch. The speaker attaches directly to the structural framing in a wall or ceiling before tape and mud are applied. **Once the seams are sanded and painted the speaker becomes completely invisible!** (See installation instructions for more details.)

Visit the Stealth Acoustics YouTube channel for Installation Videos and more!



LINEAR RESPONSE

INVISIBLE SPEAKERS & SUBWOOFERS

100% QUALITY CONTROL

Each Stealth Acoustics invisible speaker is hand-crafted to exacting quality standards using over-provisioned components and self-resetting protection circuits to ensure reliable long-term performance.

Additionally, every invisible speaker is individually tested -twice- before shipment. Every speaker is first analyzed electronically and then by a human ear to ensure top-quality sound.

*We test **EVERY** speaker we build!*



Stealth Acoustics invisible loudspeakers are always assembled by hand for ultimate care and quality control.

WARRANTY

Because LineaResponse invisible speakers are expertly designed, hand assembled, and individually tested, they offer a lifetime of worry-free performance. However, should a problem arise, Stealth stands behind each speaker it builds with comprehensive, industry-leading warranty protection for a swift resolution. Contact Stealth Acoustics for complete warranty details.

INVISIBLE
INCREDIBLE



hdav.online



We Are INVISIBLE Speakers

T 888.865.6800
F 360.424.8872



A Division of Dimensional Communications, Inc.
1220 Anderson Road | Mount Vernon, WA 98274

StealthAcoustics.com