

STEALTH

SLR 8G
LINEAR RESPONSE

STEREO INVISIBLE LOUDSPEAKER IN-WALL OR IN-CEILING



LINEAR RESPONSE

INVISIBLE SPEAKERS

The Stealth Acoustics model SLR8g is a dual-channel, two-way, full-range loudspeaker system that becomes completely invisible after installation. The loudspeaker has a rigid frame that attaches directly to standard structural framing. The paintable active diaphragm face is bonded to the frame of the speaker panel, creating an active area surrounded by a stable mounting area. Installation instructions are shown on a paper overlay that is to be removed before installation. The overlay can also be used as a cutting template for retrofitting the speakers into existing wallboard.

The SLR8g may be installed in either the wall or ceiling and on-site finishing options include latex paint, light wallpaper, fabrics and selected texture coats. There is no need for nonstandard wallboard finishing materials. Advanced finishing methods such as veneer treatments may be supported using special techniques.

The Stealth Acoustics SLR8g incorporates an acoustically coupled high quality, high-power 8" cone woofer and two direct coupled 30 mm neo-magnet high-frequency drivers. Advanced internal materials allow for smooth frequency extension to 20 kHz. When the SLR8g is installed in standard insulated 2" x 4" framing and allowed to function in a full 8 foot stud bay, frequency response below 45 Hz can be achieved. The SLR8g contains independent crossover sections and protection circuits (high-frequency and low-frequency sections) for each channel that automatically reset upon reduction of excessive amplifier power.

For proper registration, each speaker must be installed so that the surface of the **perimeter edge is flush** with the adjoining wallboard. When correctly in place, the surface of the speaker **face panel extends above** the height of the wallboard by $\frac{1}{16}$ " (1.6 mm). This is done

Recommended Applications:

Ideal for locations where space is limited such as hallways, closets, and bathrooms
Multi-Room Audio Systems
Foreground Music
Background Music

Recommended Installations:

Flush mounted in walls or ceilings constructed of wood or steel framing with $\frac{1}{2}$ " (13 mm) or thicker gypsum wallboard.

Min. Cavity Depth Required:

$2\frac{1}{2}$ " (64 mm)

Performance:

120 Watts RMS
45Hz to 20kHz (see Figure 1)
60W minimum recommended power

Protection:

Four independent self-resetting circuits (low and high-frequency each channel).

On-Site Finish Options:

Finish options include latex paint, flat finish, orange peel texture, light plaster, light wallpaper, light fabric, wood veneer, and other selected approved finishes.

to allow space for the tape and joint compound needed to blend the panel into the wall. Shims are included to allow for mounting in wallboard thicker than $\frac{1}{2}$ " (13 mm).

Stealth Acoustics' invisibility offers a powerful advantage over traditional loudspeakers because they can be placed wherever they sound best, free of visual concerns that may conflict with architectural features. Accompanying the full range panels, Stealth Acoustics offers the B22g and B30g – completely invisible companion subwoofers for extended low frequency response.

All Stealth Acoustics speakers are covered by a 17 year manufacturer's warranty.

Architectural & Engineering Specifications

The loudspeaker shall be a dual-channel two-way, full-range device, producing frequencies from 45Hz to 20kHz. The total radiating surface shall be 228 sq. in (1,470 sq. cm) and high frequency dispersion shall be a nominal 170 degrees in both horizontal and vertical planes. The loudspeaker system shall have a sensitivity of 82 dB, 1 watt / 1 meter, with a capacity of 120 watts RMS according to EIA standard RS-426-A. The loudspeaker shall have four independent self-resetting protection devices, one each for the high-frequency driver and the low-frequency driver on each channel.

The loudspeaker shall fit into walls and ceilings with wood or steel stud construction and a standard 2½" (64 mm) depth cavity. The loudspeaker shall mount directly to the structural framing and have the capability of seamlessly adjoining ½" (13 mm) or thicker gypsum wallboard. The minimum distance between framing members shall be 9½" (241 mm). Face panel finishing methods shall be consistent with normal gypsum wallboard finishing techniques and may include latex paint, light wallpaper, light fabric and other selected approved finishes.

The loudspeaker shall be the Stealth Acoustics Model SLR8g and shall carry a 17 year manufacturer's warranty.

Product Specifications

Frequency Response:

45Hz to 20kHz (see Figure 1)

Power Capacity:

120 watts RMS
60 watts minimum recommended power

Protection:

Four independent self-resetting devices
(low and high frequency each channel)

Sensitivity:

82 dB (1 watt / 1 meter)

Driver Components:

High frequency: Two 1½" (30 mm) neodymium drivers
Low-frequency: 1½" (38 mm) voice coil 8" (203 mm) woofer,
20 oz. (567 gr) ceramic magnet

System Impedance:

8Ω nominal

Polar Dispersion:

170 degrees vertical and horizontal

Dimensions:

Width: 15⅞" (403 mm)
Height: 22" (559 mm)
Mounting Depth: 2½" (64 mm)

Product Weight:

14.5 lbs. (6.5 kg)

Shipping Weight:

18 lbs. (8.1 kg) shipped each

Included Accessories:

Mounting shims
Mounting screws
Terminal wrench

Optional Accessories:

SA2400-MKII	Stealth Acoustics High Current 2-Channel Amplifier with DS PlaceSaver™
PS-22	MDF Acoustic Back Box
BX-22SLR	UL Listed Metal Back Box
MBX-22	UL Listed Metal Back Box - Adjustable
MBA-22	Concrete Back Box
MBC-22	Shim Kit
SK-1	100, 75 and 25 volt Constant Voltage Xfmr
CVXMR	

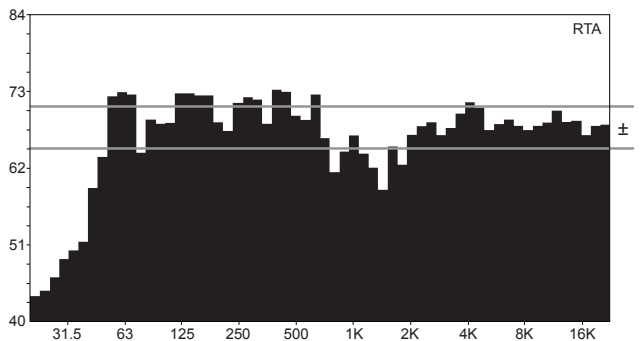
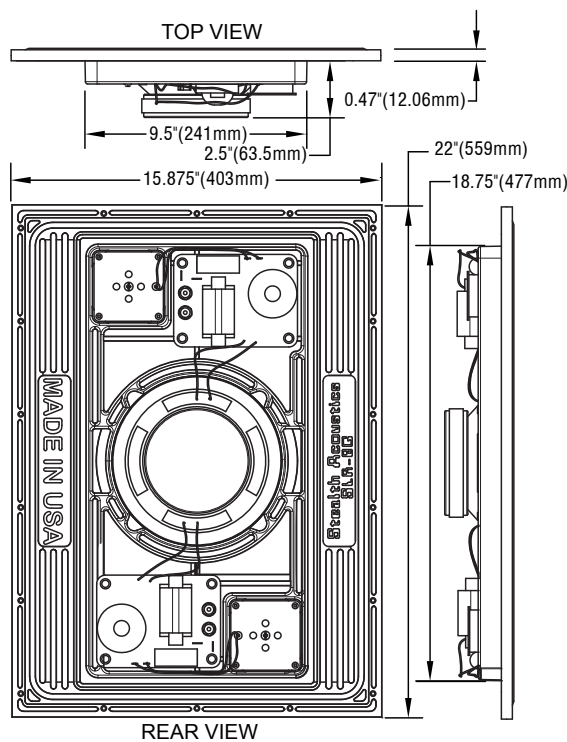

Figure 1: On-axis frequency response in standard stud wall with four coats of latex paint applied to the speaker face panel.